

# Realtime Epileptic Seizures Detection and Alert System

<sup>1</sup>S. Udhaya Shankar, <sup>2</sup>N. Vijayalakshmi

<sup>1,2</sup>Department of Electronics and Communication Engineering, Paavai Engineering College, Namakkal, Tamilnadu, India

**Abstract** - For people who have been suffering from epileptic seizures, a real time system is developed which is helpful in detecting such cases, is smart epilepsy detection and alert system is an advanced technology by which we have developed a electronic gadget. Using that kit we can save the life of the person who is really effecting with the condition. It will do the help in both the ways means not only checks the condition but also sends an SMS to the concerned doctor for the patient's live saving sake. The main aim of the project is to provide a electronic gadget for the epilepsy patients to protect themselves from the seizures and heart attacks. Not only will that it also intimate the respective doctors about the patient's condition.

**Keywords:** IoT in Healthcare, Patient Monitoring System, Machine Learning for Seizure Detection, Artificial Intelligence in Healthcare, Neurological Disorder Detection, Remote Health Monitoring, Emergency Alert System.

## I. INTRODUCTION

Our human brain consists of neuron which sends a constant level of electronic signals. But In case of any abnormality happens in the body the brain keeps on sending more electrical signal which is medically termed as electrical Storm. Using that seizure can be detected. And though many researchers joined hands together to use this method to alert the seizure that occurs within few moments for an epilepsy. A slight variation in patient's electrical activity (disruption) is more than enough to detect. Using multiple detection helps the case to get more accurate result. Micro Electromechanical Sensor (MEMS) which is one of the suitable sensors for detecting muscular convolutions which is compact and easily attachable. This accelerometer notes the seizure with accurate values. It doesn't cause discomfort to the patient.

## II. PROPOSED SYSTEM

The electronic system presented here is a wearable device which predicts the occurrence of epilepsy in a few minutes advance. The device utilizes the signals from human body to detect the occurrence of epilepsy. A Heart pulse sensor detects the heart beat rate and along with a temperature sensor can predict the occurrence of epilepsy few minutes earlier to the happening of epilepsy. And when a epilepsy occurs the

symptoms are gets detected by the MEMS accelerometer sensor and an emergency alert SMS message is to the doctor mobile through GSM modem. The patient information stored in the EEPROM is automatically sent to the doctor to know about the previous history and information about the patient.

## III. BLOCK DIAGRAM & CIRCUIT DIAGRAM

### Block diagram

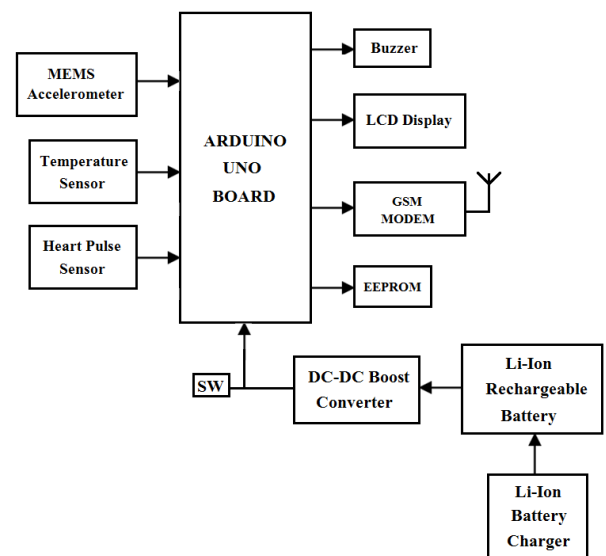

Figure 1: Block diagram

### Block diagram description

To implement all the above process we have used the following main modules, Arduino Uno board, MEMS Accelerometer, Heart Pulse Sensor, Temperature Sensor and GSM module to send an SMS alert to doctor during emergency. LCD Arduino is used for real time data monitoring and patient health status is displayed in LCD which are heart pulse, temperature and body posture movements.

Here for sensing the biometric signals three sensors are used:

1. LM35 Temperature Sensor
2. Heart Pulse Sensor (BPM)
3. ADXL335 MEMS Accelerometer



1. Heart beat rate (BPM) calculations
2. Body Temperature calculations
3. Seizure detection from MEMS accelerometer signal
4. Displaying diametric data in LCD display
5. GSM Modem SMS Communication
6. Overall supervision and sound alert using buzzer

The system requires a heart beat sensor, muscular convulsion.

All the above said parts are integrated together to arduino processor to form the device. The epilepsy prediction system can be practically implemented by incorporating the following components

**a) Heart beat sensor**

A pulse oxy meter is used as a heart beat sensor.

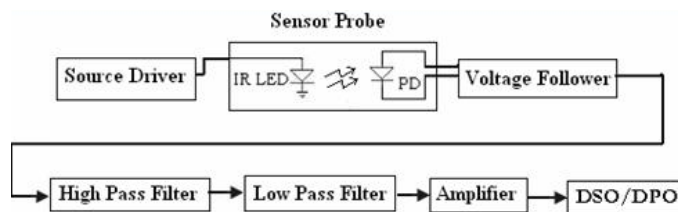

Figure 3: Heart beat sensor

**Block schematic of pulse-oxy meter**

The implementation of pulse oxy meter is by cascading several stages as shown in the figure. A high pass filter is designed with lower cutoff frequency of 15 Hz. The high pass filter is cascaded with a low pass filter designed to an upper cut off frequency of 0.5 Hz. The amplifier at the final stage raises the voltage from mV level to the required voltage range. An amplification factor of 50 is given to it.

**b) Convulsions sensor**

An accelerometer is used as a convulsion sensor. Muscular convulsions are detected using three axis mems accelerometer . The sensitivity of the sensor is set to 1.55g. The circuit is implemented as shown in the circuit diagram. The output of the sensor is filtered out sing a low pass RC filter externally. The value of R is selected as 1KΩ and C as 0.1μf.

**c) Processing unit**

The processing unit contains Arduin board with ATMEGA328 microcontroller. The microcontroller has inbuilt 8 bit ADC which is used to digitize the output from MEMS module. It also includes a comparator which is used to process the heart beat waveforms from the pulse oxy meter.

The incoming signal is processed using logics implemented in the software which runs the device. The processing unit continuously checks for symptoms in the incoming signal. As soon as it detects any abnormality, it triggers a warning vibrator and the GSM wireless transmitter.

**d) GSM module**

Using the SIM900 GSM module in the kit to send an SMS to the guardian and the doctor who will take care of the patient in the hospitals. GSM module code we have dumped in the arduino micro controller using the Arduino IDE software.

**e) Enclosure design**

The device is a wearable one (on the wrist). Hence the enclosure is designed suiting to that purpose. The enclosure can be designed in the form of a watch. The device is powered from a rechargeable Li-Ion battery storage.

Testing of Pulse oxy meter:

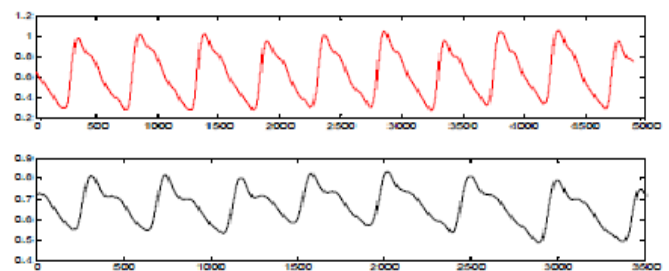

Figure 4: Output graphical wave form from pulse oxy meter

The pulse oxy meter was tested by wounding the probe of the device on the index finger of a person and the output were viewed on a DSO. The output is shown in the graph given below. The pulse oxy meter successfully detected the heart beat waveform from the patient’s index finger. The output frequency was 1.2 Hz. And the voltage level was in the range of 100 to 120 mV.

**Testing of MEMS sensor**

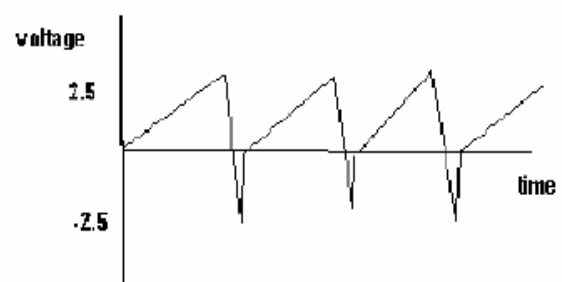

Figure 5: Testing of MEMS sensor

The MEMS sensor is connected to the body of the patient using straps. Typical epileptic seizure waveform is shown in the figure below. The sensor output is expected to be of the shape as shown below. This stage is not yet fully tested and testing is under way.

### Working of Pulse Sensor

The theory behind optical heart-rate sensors is very simple. If you've ever shined a flashlight through your fingers and observed your heartbeat pulsing, the concept of optical heart-rate pulse sensors can be easily grasped.

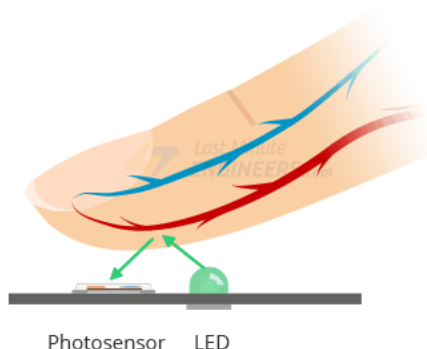

Figure 6: Pulse sensor

A pulse sensor, like any other optical heart-rate sensor, works by shining a green light (~ 550nm) on the finger and measuring the amount of reflected light with a photo sensor. This optical pulse detection technique is known as a Photoplethysmogram.

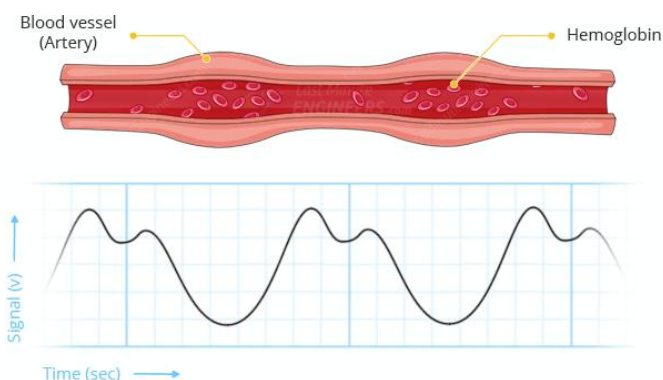

Figure 7: Testing of pulse sensor

The oxygenated hemoglobin in arterial blood has the property of absorbing green light. The redder the blood (the higher the hemoglobin), the greater the absorption of green light. With each heartbeat, blood is pumped through the finger, causing a change in the amount of reflected light, which in turn produces a waveform at the photosensor's output.

### Testing of GSM communication module

The GSM modem is directly connected to the Tx Rx pins of Arduino microcontroller board in which the software was programmed. As soon as the software detected the epileptic symptom, the transmitter was triggered. Using GSM network communication detected at a frequency of 2.4G Hz a SMS message is sent automatically. The system designed here processes the heart beat continuously and abnormalities are detected accurately. The device transmits the signal only when seizures of epilepsy are detected. The performance of the device is not restricted by movement of the patient. By using this device the patient can move freely without worries.

### V. CONCLUSION

The hardware for the epileptic seizure detection and alerting is developed using arduino and biometric sensors. This system can be made as light weight, rugged, cost-effective wearable device is developed which helps millions of victims of epilepsy around the globe. With the device in possession an epilepsy victim can move around freely like normal people sans worries. This device will help the people with epilepsy in right time by alerting and sending information to the doctor to aid treatment and medication in right time thus saving lives.

### REFERENCES

- [1] J. F. Annegers and S. P. Coan, "SUDEP: Overview of definitions and review of incidence data," *Seizure: European Journal of Epilepsy*, vol. 8,(6), pp. 347-352, 1999.
- [2] O. Devinsky, "Sudden, unexpected death in epilepsy," *New England Journal of Medicine*, vol. 365, no. 19, pp. 1801-1811, 2011.
- [3] S. Beniczky, T. Polster, T. W. Kjaer, and H. Hjalgrim, "Detection of generalized tonic-clonic seizures by a wireless wrist accelerometer: A prospective, multicenter study," *Epilepsia*, vol. 54(4), pp. 58-61, 2013.
- [4] K. V. Poppel, S. P. Fulton, A. McGregor, M. Ellis, A. Patters, and J. Wheless, "Prospective Study of the Emfit Movement Monitor," *J Child Neurol*, vol. 00(0), pp. 1-3, 2013.
- [5] S. Gouravajhala, D. Wang, L. Khuon, and F. Bao, "EpSMART: Epileptic seizure monitoring with alerts in real time: A tablet-based Android application for a real-time multi-modal seizure detection system," in *Bioinformatics and Biomedicine Workshops (BIBMW), 2012 IEEE International Conference on*, 2012, pp. 959-961.



- [6] K. Cuppens, B. Vanrumste, B. Ceulemans, L. Lagae, and S. Van Huffel, "Detection of epileptic seizures using video data," in *Intelligent Environments (IE)*, 2010 Sixth International Conference on, 2010, pp. 372-373.
- [7] M.-Z. Poh, T. Loddenkemper, C. Reinsberger, N. C. Swenson, S. Goyal, M. C. Sabtala, J. R. Madsen, and R. W. Picard, "Convulsive seizure detection using a wrist-worn electrodermal activity and accelerometry biosensor," *Epilepsia*, vol. 53, no. 5, pp. 93-97, 2012.
- [8] F. Masse, J. Penders, A. Serteyn, M. van Bussel, and J. Arends, "Miniaturized wireless ECG-monitor for real-time detection of epileptic seizures," in *Wireless Health 2010*, ser. WH '10. New York, NY, USA: ACM, 2010, pp. 111-117.
- [9] G. de Bruijne, P. Sommen, and R. Aarts, "Detection of epileptic seizures through audio classification," in *4th European Congress of the International Federation for Medical and Biological Engineering (IFMBE)*, 2008.

**Citation of this Article:**

S. Udhaya Shankar, & N. Vijayalakshmi. (2026). Realtime Epileptic Seizures Detection and Alert System. *International Current Journal of Engineering and Science (ICJES)*, 5(3), 11-15. Article DOI: <https://doi.org/10.47001/ICJES/2026.503003>

\*\*\*\*\*